

	H HRC
178279	<62
vc = m/min.	
178279	200-400

应用:
适用铲磨

Toleranz

Durchmesser- bereich	Schneiden- \varnothing $\varnothing d_1$ (g7)	Schaft- \varnothing $\varnothing d_2$ (h5)
$d \leq 3$	-0,002	0
$3 < d \leq 6$	-0,012	-0,004
$6 < d \leq 10$	-0,004	0
$10 < d \leq 18$	-0,016	-0,005
	-0,005	0
	-0,020	-0,006
	-0,006	0
	-0,024	-0,008

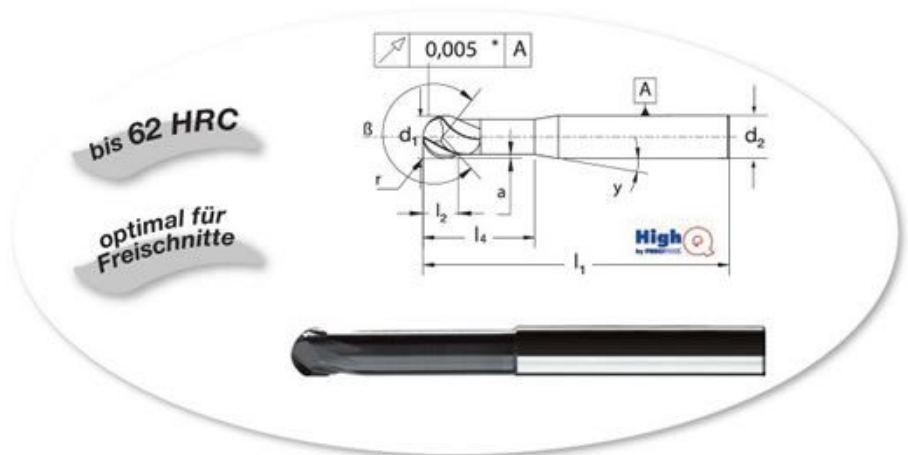

178279 HighQ, 整体硬质合金, 中型, TiAlN涂层

d ₁ (g7) mm	178279 (RG 1750)	r mm	l ₁ mm	l ₂ mm	l ₄ mm	d ₂ (h5) mm	a mm	y (°)	fz mm/齿
3,00	●	1,50	65	2,1	25	6	0,150	15	0,020-0,035
4,00	●	2,00	65	2,8	25	6	0,200	15	0,025-0,040
5,00	○	2,50	79	3,5	30	6	0,300	45	0,030-0,045
6,00	●	3,00	79	4,1	37	6	0,360	45	0,030-0,050
8,00	●	4,00	90	5,5	46	8	0,480	45	0,040-0,050
10,00	○	5,00	102	6,9	55	10	0,600	45	0,040-0,060
12,00	○	6,00	120	8,2	72	12	0,720	45	0,050-0,060
16,00	○	8,00	120	11,0	72	16	0,960	45	0,050-0,080

我们的服务

特快热线: 021-33522999

传真: 021-33522345

邮箱: info@precitool.com.cn

周一至周五: 8:30—17:00

通过这条热线您可以在办公时间随时联系到您的precitool.

无论何时, 当您在产品使用中出现问题的时候, 我们都会积极的配合为您解决

你能获得的好处: 高性价比的优质产品 高效的采购流程 高速的服务体系



*说明: 只供应标准库存 (且可包装的物品). 我们保证在我们承诺的供货期内交货. 但是运输期间由于货运公司造成的延误我们不承担责任.

整体硬质合金球头铣刀

PRECITOOL
PRÄZISIONSWERKZEUGE

	P N/mm ²	H HRC	M N/mm ²	K HB
178415	<1200	<60	<850	<300
vc = m/min.				
178415	115-240	50-60	65-105	145-240



178415 PRECITOOL, 整体硬质合金, 长型 ALCRONA涂层

d ₁ (h9) mm	178415 (RG 1731)	r mm	l ₁ mm	l ₂ mm	d ₂ (h6) mm	fz mm/齿
2,00	●	1,00	57	6,00	6,0	0,005-0,010
3,00	●	1,50	57	8,00	6,0	0,010-0,016
4,00	●	2,00	57	11,00	6,0	0,018-0,024
5,00	●	2,50	57	13,00	6,0	0,020-0,026
6,00	●	3,00	57	13,00	6,0	0,024-0,029
8,00	●	4,00	63	19,00	8,0	0,032-0,042
10,00	●	5,00	72	22,00	10,0	0,038-0,053
12,00	●	6,00	83	26,00	12,0	0,046-0,063
14,00	●	7,00	83	26,00	14,0	0,046-0,063
16,00	●	8,00	92	32,00	16,0	0,054-0,079
18,00	●	9,00	92	32,00	18,0	0,054-0,079
20,00	●	10,00	104	38,00	20,0	0,066-0,097



整体硬质合金球头铣刀

PRECITOOL
PRÄZISIONSWERKZEUGE

	P N/mm ²	H HRC	M N/mm ²	K HB
178430	<1200	<60	<850	<300
178435	<1200	<60	<850	<300
vc = m/min.				
178430	50-110	20-30	30-45	76-115
178435	90-180	35-45	50-75	105-180



178430 PRECITOOL, 整体硬质合金, 超长型

178435 PRECITOOL, 整体硬质合金, 超长型, ALCRONA涂层

d ₁ (h9) × l ₂ mm	178430 (RG 1731)	178435 (RG 1731)	r mm	l ₁ mm	d ₂ (h6) mm	fz mm/齿
3,00 × 20	●	●	1,50	57	6,0	0,003-0,010
4,00 × 20	●	●	2,00	57	6,0	0,006-0,018
5,00 × 30	○	●	2,50	75	6,0	0,007-0,020
6,00 × 30	●	●	3,00	75	6,0	0,009-0,024
6,00 × 40	●	●	3,00	100	6,0	0,009-0,024
8,00 × 30	○	●	4,00	75	8,0	0,014-0,032
8,00 × 40	●	●	4,00	100	8,0	0,014-0,032
10,00 × 30	●	●	5,00	75	10,0	0,018-0,038
10,00 × 40	●	●	5,00	100	10,0	0,018-0,038
12,00 × 45	●	●	6,00	100	12,0	0,022-0,046
12,00 × 65	○	○	6,00	150	12,0	0,022-0,046
14,00 × 45	○	○	7,00	100	14,0	0,022-0,046
14,00 × 65	○	○	7,00	150	14,0	0,022-0,046
16,00 × 45	○	○	8,00	100	16,0	0,027-0,054
16,00 × 65	○	○	8,00	150	16,0	0,027-0,054
16,00 × 90	○	○	8,00	150	16,0	0,027-0,054
18,00 × 45	○	○	9,00	100	18,0	0,027-0,054
18,00 × 65	○	○	9,00	150	18,0	0,027-0,054
20,00 × 45	○	○	10,00	100	20,0	0,033-0,066
20,00 × 65	○	○	10,00	150	20,0	0,033-0,066
20,00 × 90	○	○	10,00	150	20,0	0,033-0,066



	P N/mm ²	H HRC	M N/mm ²	K HB
178455	<1200	<60	<850	<300
vc = m/min.				
178455	60-120	30-50	50-75	100-180

备注:
超强螺旋角, 获得特别理想的表面光洁度

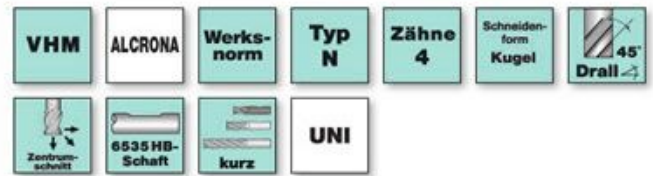

178455 PRECITOOL, 整体硬质合金, 短型, ALCRONA涂层

d ₁ (h9) mm	178455 (RG 1731)	r mm	l ₁ mm	l ₂ mm	d ₃ (h6) mm	fz mm/齿
6,00	●	3,00	54	10,00	6,0	0,015-0,080
8,00	●	4,00	58	12,00	8,0	0,015-0,080
10,00	●	5,00	66	14,00	10,0	0,025-0,120
12,00	●	6,00	73	16,00	12,0	0,025-0,120
14,00	●	7,00	75	18,00	14,0	0,030-0,150
16,00	○	8,00	82	22,00	16,0	0,030-0,150
20,00	○	10,00	92	26,00	20,0	0,040-0,200



	P N/mm ²	H HRC	M N/mm ²	K HB
178465	<1200	<60	<850	<300
vc = m/min.				
178465	60-120	30-50	50-75	100-180

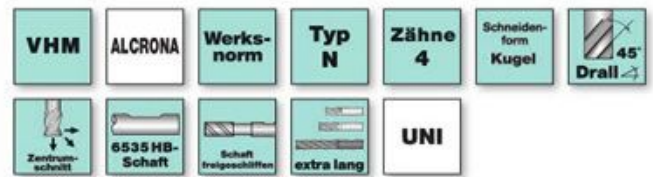

178465 PRECITOOL, 整体硬质合金, 超长型, ALCRONA涂层

d ₁ (h9) mm	178465 (RG 1731)	r mm	l ₁ mm	l ₂ mm	l ₄ mm	d ₃ mm	d ₂ (h6) mm	fz mm/齿
6,00	●	3,00	100	10,00	40	5,8	6,0	0,015-0,080
8,00	●	4,00	100	12,00	40	7,8	8,0	0,015-0,080
10,00	●	5,00	100	14,00	40	9,7	10,0	0,025-0,120
12,00	●	6,00	100	16,00	40	11,7	12,0	0,025-0,120
14,00	○	7,00	100	18,00	40	13,7	14,0	0,030-0,150
16,00	○	8,00	150	22,00	70	15,6	16,0	0,030-0,150
20,00	○	10,00	150	26,00	70	19,6	20,0	0,040-0,200



整体硬质合金球头铣刀

	H HRC
178470	<62
vc = m/min.	
178470	200-400

应用:
适用于5轴加工

Toleranz

Durchmesserbereich	Schneiden- \varnothing $\varnothing d_1$ (g7)	Schaft- \varnothing $\varnothing d_2$ (h5)
$3 < d \leq 6$	-0,004 -0,016	0 -0,005
$6 < d \leq 10$	-0,005 -0,020	0 -0,006
$10 < d \leq 18$	-0,006 -0,024	0 -0,008



178470 HighQ, 整体硬质合金, 短型/中型/长型, TiAlN涂层

d_1 (g7) × l_1 mm	178470 (RG 1750)	r mm	l_2 mm	l_4 mm	d_2 (h5) mm	a mm	y (°)	fz mm/齿	d_1 (g7) × l_1 mm	178470 (RG 1750)	r mm	l_2 mm	l_4 mm	d_2 (h5) mm	a mm	y (°)	fz mm/齿
6,00 × 64	●	3,00	6	25	6	0,200	—	0,065-0,125	10,00 × 100	○	5,00	10	55	10	0,300	—	0,085-0,135
6,00 × 78	○	3,00	6	35	6	0,200	—	0,065-0,125	10,00 × 120	○	5,00	10	30	12	0,300	2	0,085-0,135
6,00 × 100	●	3,00	6	25	8	0,200	2	0,065-0,125	12,00 × 78	○	6,00	12	35	12	0,300	—	0,100-0,140
8,00 × 64	○	4,00	8	25	8	0,300	—	0,080-0,130	12,00 × 100	○	6,00	12	55	12	0,300	—	0,100-0,140
8,00 × 78	●	4,00	8	35	8	0,300	—	0,080-0,130	12,00 × 120	●	6,00	12	40	16	0,300	5	0,100-0,140
8,00 × 100	●	4,00	8	50	8	0,300	—	0,080-0,130	16,00 × 100	●	8,00	20	50	16	0,300	—	0,100-0,150
8,00 × 120	○	4,00	8	30	10	0,300	2	0,080-0,130	16,00 × 150	○	8,00	20	100	16	0,300	—	0,100-0,150
10,00 × 78	●	5,00	10	35	10	0,300	—	0,085-0,135	—	—	—	—	—	—	—	—	—

整体硬质合金球头铣刀, 铜

	N N/mm ²
178472	Kupfer
vc = m/min.	
178472	200-350

Toleranz

Durchmesserbereich	Schneiden- \varnothing $\varnothing d_1$ (g7)	Schaft- \varnothing $\varnothing d_2$ (h5)
$d \leq 3$	-0,002 -0,012	0 -0,004
$3 < d \leq 6$	-0,004 -0,016	0 -0,005
$6 < d \leq 10$	-0,005 -0,020	0 -0,006
$10 < d \leq 18$	-0,006 -0,024	0 -0,008

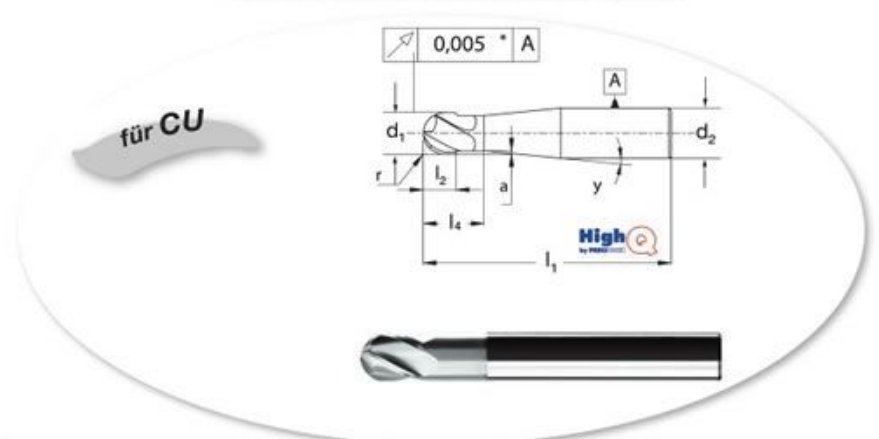

178472 HighQ, 整体硬质合金, 短型 CrCN涂层

d_1 (g7) mm	178472 (RG 1750)	r mm	l_1 mm	l_2 mm	l_4 mm	d_2 (h5) mm	a mm	y (°)	fz mm/齿	d_1 (g7) mm	178472 (RG 1750)	r mm	l_1 mm	l_2 mm	l_4 mm	d_2 (h5) mm	a mm	y (°)	fz mm/齿
3,00	○	1,50	50	4	12	3	0,050	—	0,015-0,020	10,00	●	5,00	79	12	25	10	0,100	—	0,055-0,075
4,00	○	2,00	65	5	16	6	0,050	15	0,020-0,030	12,00	○	6,00	79	15	30	12	0,150	—	0,100-0,130
5,00	○	2,50	65	6	19	6	0,100	15	0,025-0,035	14,00	○	7,00	90	24	35	14	0,150	—	0,120-0,180
6,00	●	3,00	65	7	20	6	0,100	—	0,030-0,040	16,00	○	8,00	100	28	40	16	0,150	—	0,150-0,250
8,00	○	4,00	65	9	22	8	0,100	—	0,040-0,060	—	—	—	—	—	—	—	—	—	—

● = 德国中央仓库库存
○ = 德国工厂仓库供货

	P N/mm ²	M N/mm ²	K HB	S N/mm ²		N N/mm ²		
178710	<1620	<1000	<300	钛 <1200	镍 <1200	钢<350 黄铜<700	铝合金	热塑性塑料 热固性塑料 纤维增强塑料
178715								
178720								
178725								
178730								
178735								
vc = m/min.								
178710	40-120	30-35	70-100	40-120	40-170	200-250	300-800	70-200
178715	70-190	60-90	90-175	60-190	39-260	360-410	400-900	90-350
178720	40-120	30-35	70-100	40-120	40-170	200-250	300-800	70-200
178725	70-190	60-90	90-175	60-190	39-260	360-410	400-900	90-350
178730	40-120	30-35	70-100	40-120	40-170	200-250	300-800	70-200
178735	70-190	60-90	90-175	60-190	39-260	360-410	400-900	90-350

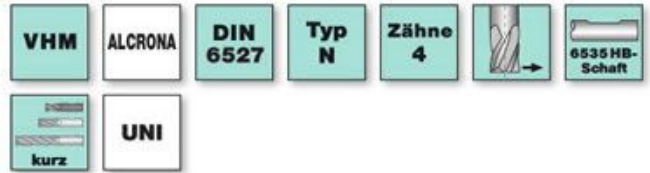

技术说明

HB-刀杆 从 d₁ = 6,00 mm起

178710 PRECITOOL, 整体硬质合金, 尖角 60°

178715 PRECITOOL, 整体硬质合金, 尖角 60°, ALCRONA涂层

d ₁ mm	178710 (RG 1737)	178715 (RG 1737)	l ₁ mm	d ₂ (h6) mm	fz mm/齿
4,00	●	●	54	4,0	0,008-0,015
6,00	●	●	57	6,0	0,013-0,025
8,00	●	●	63	8,0	0,020-0,040
10,00	●	●	72	10,0	0,027-0,050
12,00	●	●	83	12,0	0,035-0,065
16,00	●	●	92	16,0	0,050-0,090
20,00	●	●	104	20,0	0,060-0,120



178720 PRECITOOL, 整体硬质合金, 尖角 90°

178725 PRECITOOL, 整体硬质合金, 尖角 90°, ALCRONA涂层

d ₁ mm	178720 (RG 1737)	178725 (RG 1737)	l ₁ mm	d ₂ (h6) mm	fz mm/齿
4,00	●	●	54	4,0	0,008-0,015
6,00	●	●	57	6,0	0,013-0,025
8,00	●	●	63	8,0	0,020-0,040
10,00	●	●	72	10,0	0,027-0,050
12,00	●	●	83	12,0	0,035-0,065
16,00	●	●	92	16,0	0,050-0,090
20,00	●	●	104	20,0	0,060-0,120



178730 PRECITOOL, 整体硬质合金, 尖角 120°

178735 PRECITOOL, 整体硬质合金, 尖角 120°, ALCRONA涂层

d ₁ mm	178730 (RG 1737)	178735 (RG 1737)	l ₁ mm	d ₂ (h6) mm	fz mm/齿
4,00	○	○	54	4,0	0,008-0,015
6,00	●	●	57	6,0	0,013-0,025
8,00	●	●	63	8,0	0,020-0,040
10,00	●	●	72	10,0	0,027-0,050
12,00	●	●	83	12,0	0,035-0,065
16,00	○	●	92	16,0	0,050-0,090
20,00	○	●	104	20,0	0,060-0,120



	P N/mm ²	K HB	S N/mm ²	N N/mm ²	
178760				铝 -600	铜, 黄铜
178761	<850	<200			
178762					
178765			钛, 镍<900		
178766	<1000	<300			
178767					

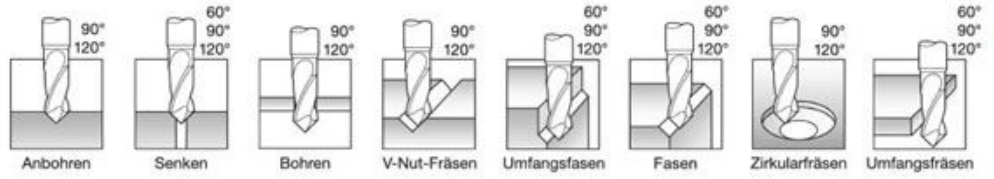
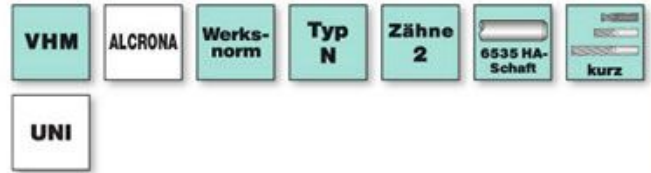

178760 PRECITOOL, 整体硬质合金, 尖角60°

178765 PRECITOOL, 整体硬质合金, 尖角60° ALCRONA涂层

d ₁ (h9) mm	178760 (RG 1732)	178765 (RG 1732)	l ₁ mm	l ₂ mm	d ₂ (h6) mm
3,00	●	●	50	6,00	4,0
4,00	●	●	50	8,00	5,0
5,00	●	●	50	10,00	6,0
6,00	●	●	60	12,00	8,0
8,00	●	●	70	16,00	10,0
10,00	●	●	70	18,00	12,0
12,00	●	●	70	20,00	12,0
16,00	●	○	80	26,00	16,0
20,00	○	○	100	32,00	20,0



PRECITOOL 178765

178761 PRECITOOL, 整体硬质合金, 尖角90°

178766 PRECITOOL, 整体硬质合金, 尖角90°, ALCRONA涂层

d ₁ (h9) mm	178761 (RG 1732)	178766 (RG 1732)	l ₁ mm	l ₂ mm	d ₂ (h6) mm
3,00	●	●	50	6,00	4,0
4,00	●	●	50	8,00	5,0
5,00	●	●	50	10,00	6,0
6,00	●	●	60	12,00	8,0
8,00	●	●	70	16,00	10,0
10,00	●	●	70	18,00	12,0
12,00	●	●	70	20,00	12,0
16,00	●	●	80	26,00	16,0
20,00	●	○	100	32,00	20,0



PRECITOOL 178766

178762 PRECITOOL, 整体硬质合金, 尖角120°

178767 PRECITOOL, 整体硬质合金, 尖角120°, ALCRONA涂层

d ₁ (h9) mm	178762 (RG 1732)	178767 (RG 1732)	l ₁ mm	l ₂ mm	d ₂ (h6) mm
3,00	○	○	50	6,00	4,0
4,00	○	○	50	8,00	5,0
5,00	○	●	50	10,00	6,0
6,00	●	○	60	12,00	8,0
8,00	●	●	70	16,00	10,0
10,00	○	○	70	18,00	12,0
12,00	○	○	70	20,00	12,0
16,00	●	○	80	26,00	16,0
20,00	○	○	100	32,00	20,0



PRECITOOL 178767

技术说明:

具有同步截面的圆柱形刀柄 符合DIN 1835 B / h6.



**HM-
WPL**

应用:

常用扩孔铣刀配套用可转位式刀片, 适用于正反向倒角, 去毛刺和扩孔

备注:

配套垫片及螺丝参见 241080.

匹配的可转位刀片

SPMT 09T308 订货编号: 120408:

P25: WL4040

铝: H13A

Kat.-Nr. 178800:

Winkel	D max	D min
15	21,0	6,0
30	22,0	8,5
45	23,0	12,0
60	23,2	15,2
75	22,2	18,0

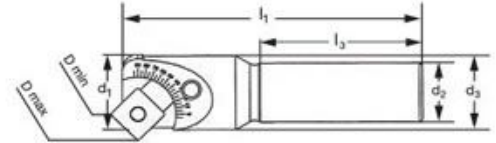

178800 PRECITOOL, 适用 SPMT 09T

d ₂ mm	178800 (RG 1735)	l ₁ mm	l ₃ mm	d ₁ mm	d ₃ mm
16,00	●	86,2	49	19,5	18,75



Kat.-Nr. 178805:

Winkel	D max	D min
15	28,4	7,2
30	30,4	11,4
45	31,4	15,8
60	31,2	20,0
75	30,0	24,4

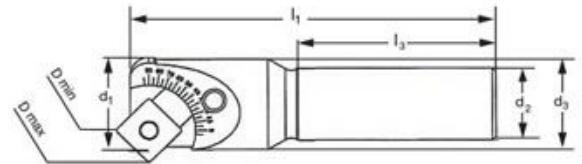

178805 PRECITOOL, 适用 SPMT 12

d ₂ mm	178805 (RG 1735)	l ₁ mm	l ₃ mm	d ₁ mm	d ₃ mm
20,00	●	98,0	53	26,0	25,00



178807 PRECITOOL, 适用 SPMT 09T 和 SPMT 12

d ₂ mm	178807 (RG 1735)	l ₁ mm	l ₃ mm	d ₁ mm	d ₃ mm
M12	○	65,0	19	19,5	20,50
M16	○	45,0	24,2	28,8	16,00

