

技术说明:

- 可加工左旋和右旋螺纹, 同216500
- 锥体-空心柄符合 DIN 69893-A标准, 或根据 DIN 69893-AD标准, 通过冷却液管进行内部冷却
适用自动更换工具

**DIN
69893
A**

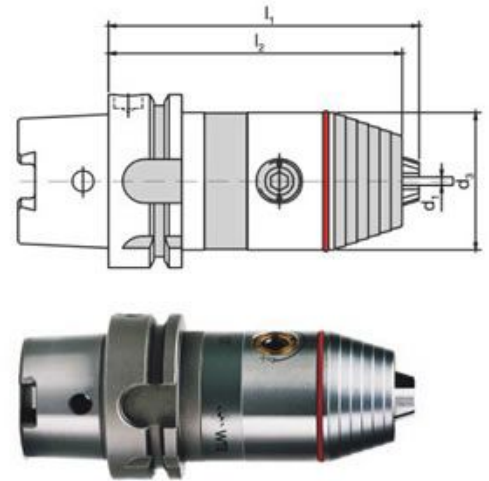

216560 DIN 69893 A

HSK/d ₁ mm	216560 (RG 2182)	d ₁ mm	d ₃ mm	max. l ₁ mm	l ₂ mm	质量 kg
32/8	○	0,3-8	36	93	90	0,5
40/8	○	0,3-8	36	94	91	0,5
50/8	○	0,3-8	36	98	95	0,7
50/13	○	0,5-13	50	122	116	1,4
50/16	○	2,5-16	57	127	121	1,7
63/8	●	0,3-8	36	99	96	1,1
63/13	●	0,5-13	50	110	104	1,7
63/16	●	2,5-16	57	115	109	1,9
80/13	○	0,5-13	50	115	109	2,1
80/16	○	2,5-16	57	120	114	2,3
100/13	○	0,5-13	50	117	111	3,1
100/16	○	2,5-16	57	122	116	3,3

**DIN
69893
A/D**



Dichtscheibe WTE 13 2,05 mm im Lieferumfang enthalten. Für Kühlikanalbohrer 3-6 mm, mit glattem Schaft nach DIN 6535 Form HA



Dichtscheibe WTE 13 4,2 mm im Bohrfutterkopf eingebaut. Für Kühlikanalbohrer 6-13 mm, mit glattem Schaft nach DIN 6535 Form HA

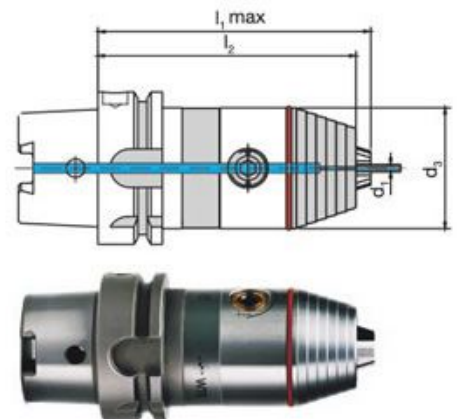

216570 DIN 69893 A/D

HSK/d ₁ mm	216570 (RG 2182)	d ₁ mm	d ₃ mm	max. l ₁ mm	l ₂ mm	质量 kg
32/8	○	0,3-8	36	93	90	0,5
40/8	○	0,3-8	36	94	91	0,5
50/8	○	0,3-8	36	98	95	0,7
50/13	○	0,5-13	50	122	116	1,4
50/16	○	2,5-16	57	127	121	1,7
63/8	●	0,3-8	36	99	96	1,1
63/13	●	0,5-13	50	110	104	1,7
63/16	●	2,5-16	57	115	109	1,9
80/13	○	0,5-13	50	115	109	2,1
80/16	○	2,5-16	57	120	114	2,3
100/13	○	0,5-13	50	117	111	3,1
100/16	○	2,5-16	57	122	116	3,3

技术说明:

- 可加工左旋和右旋螺纹, 同 216500
- 圆柄根据 DIN 69880 / VDI 3425标准, 通过3个球状喷嘴进行冷却, 或圆柄根据 DIN 69880 / VDI 3425 标准通过中间进行冷却



还可供应可以朝柄方向 (工件侧面) 旋转180度的钻夹头

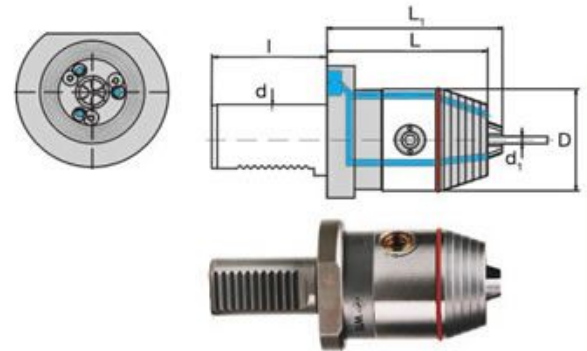

216580 DIN 69880 带3个 球状喷嘴

型号	216580 (RG 2182)	d×l mm	d ₁ mm	D mm	L mm	L ₁ max mm	质量 kg
16/8	○	16×32	0,3-8	40	60	63	0,6
20/8	○	20×40	0,3-8	40	60	63	0,7
20/13	○	20×40	0,5-13	57	82	88	1,7
25/8	○	25×48	0,3-8	40	60	63	0,8
30/8	○	30×55	0,3-8	40	60	63	1,0
30/13	●	30×55	0,5-13	57	82	88	2,1
30/16	●	30×55	2,5-16	57	82	93	2,1

型号	216580 (RG 2182)	d×l mm	d ₁ mm	D mm	L mm	L ₁ max mm	质量 kg
40/8	○	40×63	0,3-8	40	65	68	1,7
40/13	●	40×63	0,5-13	57	85	91	2,6
40/16	●	40×63	2,5-16	57	85	96	2,6
50/13	○	50×78	0,5-13	57	85	91	3,4
50/16	●	50×78	2,5-16	57	85	96	3,4
60/16	○	60×94	2,5-16	57	93	104	4,9
-	-	-	-	-	-	-	-



Dichtscheibe WTE 13 2,05 mm im Lieferumfang enthalten. Für Kühlikanalbohrer 3-6 mm, mit glattem Schaft nach DIN 6535 Form HA



Dichtscheibe WTE 13 4,2 mm im Bohrfutterkopf eingebaut. Für Kühlikanalbohrer 6-13 mm, mit glattem Schaft nach DIN 6535 Form HA

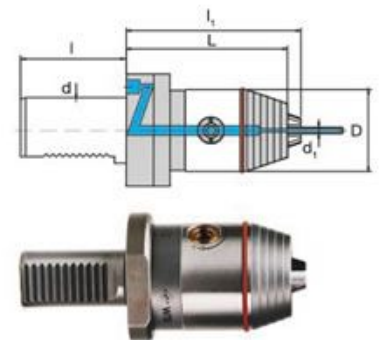

216590 DIN 69880 带内冷

型号	216590 (RG 2182)	d×l mm	d ₁ mm	D mm	L mm	L ₁ max mm	质量 kg
16/8	○	16×32	0,3-8	36	68	71	0,6
20/8	○	20×40	0,3-8	36	68	71	0,7
20/13	○	20×40	0,5-13	50	90	96	1,7
25/8	○	25×48	0,3-8	36	68	71	0,8
30/8	○	30×55	0,3-8	36	68	71	1,1
30/13	●	30×55	0,5-13	50	90	96	1,8
30/16	●	30×55	2,5-16	57	95	101	2,0

型号	216590 (RG 2182)	d×l mm	d ₁ mm	D mm	L mm	L ₁ max mm	质量kg
40/8	○	40×63	0,3-8	36	68	71	1,5
40/13	○	40×63	0,5-13	50	90	96	2,3
40/16	●	40×63	2,5-16	57	95	101	2,5
50/13	○	50×78	0,5-13	50	90	96	3,0
50/16	○	50×78	2,5-16	57	95	101	3,3
60/16	○	60×94	2,5-16	57	95	101	4,9
-	-	-	-	-	-	-	-