

高速钢铝钻槽铣刀

PRECITOOL
PRÄZISIONSWERKZEUGE

	P N/mm ²	H HRC	M N/mm ²	K HB	S N/mm ²	N N/mm ²	
162000	<1200	<60	<750	<300	钛<1200	铝<600	黄铜 <600
162005							
vc = m/min.							
162000	10-30	3-5	10-20	10-20	5-7	35-150	30-60
162005	20-60	7-10	30-40	35-50	10-25	100-210	75-100



162000 PRECITOOL, 高速钢铝, 短型, 刃口锋利

162005 PRECITOOL, 高速钢铝, 短型, 刃口锋利, ALCRONA 涂层

d ₁ (h10) mm	162000 (RG 1603)	162005 (RG 1602)	l ₁ mm	l ₂ mm	d ₃ mm	d ₂ (h6) mm	fz mm/齿
2,0	●	●	48	4	—	6,0	0,001-0,002
2,5	●	●	49	5	—	6,0	0,001-0,002
3,0	●	●	49	5	—	6,0	0,003-0,004
4,0	●	●	51	7	—	6,0	0,006-0,008
5,0	●	●	52	8	—	6,0	0,007-0,010
6,0	●	●	52	8	5,5	6,0	0,009-0,013
8,0	●	●	55	11	7,5	8,0	0,014-0,019
10,0	●	●	63	13	9,0	10,0	0,018-0,025
12,0	●	●	73	16	11,0	12,0	0,022-0,030
14,0	●	●	73	16	—	12,0	0,022-0,030
16,0	●	●	79	19	15,0	16,0	0,027-0,038
18,0	○	●	79	19	—	16,0	0,027-0,038
20,0	●	○	88	22	19,0	20,0	0,033-0,045
22,0	○	●	88	22	—	20,0	0,033-0,045
25,0	○	○	102	26	24,0	25,0	0,033-0,045

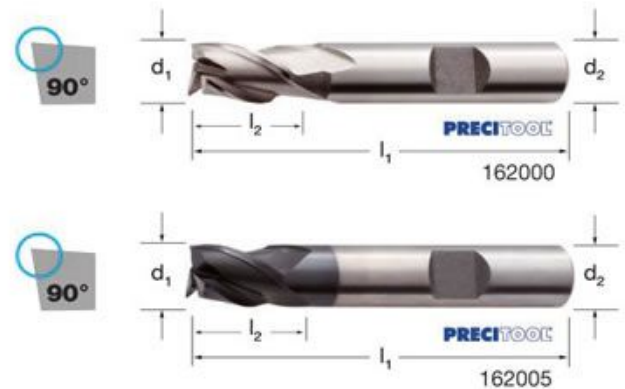

高速钢铝钻槽铣刀

PRECITOOL
PRÄZISIONSWERKZEUGE

	P N/mm ²	H HRC	M N/mm ²	K HB	S N/mm ²	N N/mm ²	
162400	<1200	<60	<750	<300	钛<1200	铝<600	黄铜 <600
162550							
vc = m/min.							
162400	10-30	3-5	10-20	10-20	5-7	35-150	30-60
162550	20-60	7-10	30-40	35-50	10-25	100-210	75-100

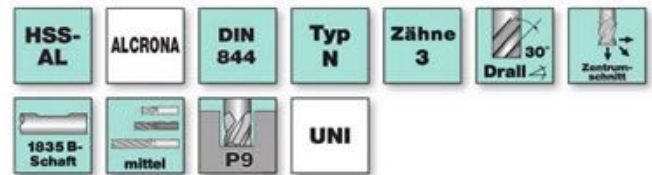

162400 PRECITOOL, 高速钢铝, 中型, 刃口锋利

162550 PRECITOOL, 高速钢铝, 中型, 刃口锋利, ALCRONA涂层

d ₁ (e8) mm	162400 (RG 1605)	162550 (RG 1605)	l ₁ mm	l ₂ mm	d ₂ (h6) mm	fz mm/齿
3,0	●	●	52	8	6,0	0,003-0,004
4,0	●	●	55	11	6,0	0,006-0,008
4,5	●	—	55	11	6,0	0,006-0,008
5,0	●	●	57	13	6,0	0,007-0,010
5,5	●	—	57	13	6,0	0,007-0,010
6,0	●	●	57	13	6,0	0,009-0,013
7,0	●	—	60	16	8,0	0,009-0,013
8,0	●	●	69	19	8,0	0,014-0,019
9,0	●	—	69	19	10,0	0,014-0,019
10,0	●	●	72	22	10,0	0,018-0,025
11,0	●	—	79	22	12,0	0,018-0,025
12,0	●	●	83	26	12,0	0,022-0,030
13,0	●	—	83	26	12,0	0,022-0,030
14,0	●	●	83	26	12,0	0,022-0,030
15,0	●	—	83	26	16,0	0,022-0,030
16,0	●	●	92	32	16,0	0,027-0,038
18,0	●	●	92	32	16,0	0,027-0,038
20,0	●	●	104	38	20,0	0,033-0,045
22,0	●	—	104	38	20,0	0,033-0,045
24,0	●	—	121	45	25,0	0,033-0,045
25,0	●	—	121	45	25,0	0,033-0,045

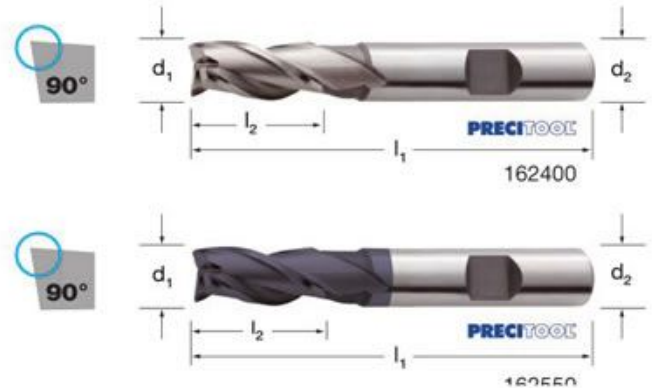

	P N/mm ²	M N/mm ²	K HB
162575	<1000	<750	<300
vc = m/min.			
162575	20-75	20-40	35-50

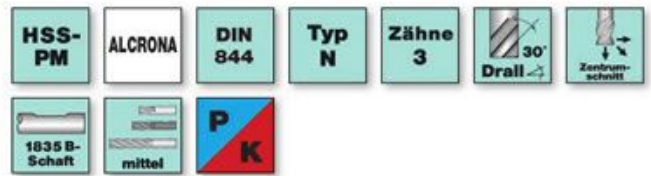

162575 PRECITOOL, 粉末高速钢, 中型, 刃口锋利, ALCRONA涂层

d ₁ mm	162575 (RG 1605)	l ₁ mm	l ₂ mm	d ₂ mm	fz mm/齿
2,00	○	51	7	6,0	0,008-0,010
3,00	○	52	8	6,0	0,008-0,010
4,00	○	55	11	6,0	0,008-0,010
5,00	○	57	13	6,0	0,008-0,010
6,00	○	57	13	6,0	0,021-0,025
7,00	○	66	16	10,0	0,021-0,025
8,00	○	69	19	10,0	0,036-0,040
10,00	○	72	22	10,0	0,036-0,048
12,00	○	83	26	12,0	0,052-0,080
16,00	○	92	32	16,0	0,052-0,080
18,00	○	92	32	16,0	0,052-0,080
20,00	○	104	38	20,0	0,052-0,080



高速钢铝钻槽铣刀

	P N/mm ²	K HB
162650	<1200	<300
162655	<1200	<300
vc = m/min.		
162650	5-20	8-15
162655	15-50	25-40

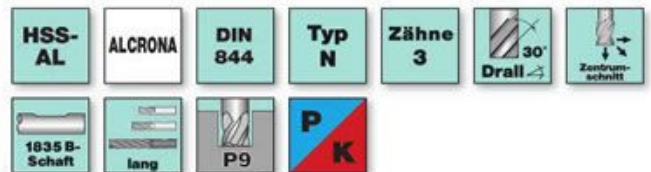

162650 PRECITOOL, 高速钢铝, 长型, 刃口锋利

162655 PRECITOOL, 高速钢铝, 长型, 刃口锋利, ALCRONA涂层

d ₁ (e8) mm	162650 (RG 1603)	162655 (RG 1602)	l ₁ mm	l ₂ mm	d ₂ (h6) mm	fz mm/齿
2,0	●	●	54	10	6,0	0,001-0,002
3,0	●	●	56	12	6,0	0,002-0,003
4,0	●	●	63	19	6,0	0,003-0,005
5,0	●	●	68	24	6,0	0,005-0,006
6,0	●	●	68	24	6,0	0,006-0,008
8,0	●	●	82	38	8,0	0,010-0,012
10,0	●	●	95	45	10,0	0,013-0,015
12,0	●	●	110	53	12,0	0,016-0,018
14,0	●	●	110	53	12,0	0,016-0,018
16,0	●	●	123	63	16,0	0,020-0,023
18,0	●	●	123	63	16,0	0,020-0,023
20,0	●	●	141	75	20,0	0,023-0,028

