

技术说明:

刀杆由700-800 N/mm²强度的钢制成。铣面和加工倒角。焊接 DIN-ISO 硬质合金刀片。
 研磨前刀面和后刀面。针对粗加工或者切削强度大的加工，我们推荐使用474900手动毛刷进行刃口钝化。

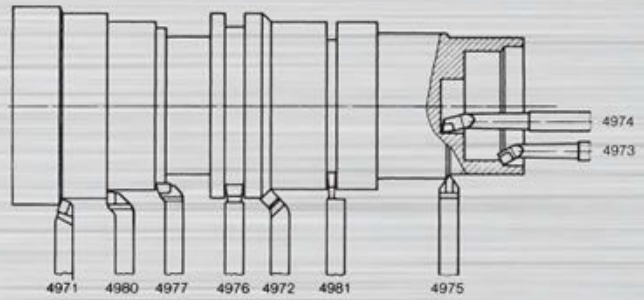

每款硬质合金材料的应用

P20 用于切削钢/中等粗加工，具有中等切削速度和进给量
 K20 用于切削铸铁 (GG至250HB) 有色金属。通用于所有低密度材料

直头车刀



HM DIN 4971 ISO 1

194020 PRECITOOL, 右向 P20

194060 PRECITOOL, 右向 K20

h×b mm	194020 (RG 1932)	194060 (RG 1932)	l ₁ mm	ISO/DIN-硬质合金刀片
10×10	●	○	90	A8
12×12	●	●	100	A10
16×16	●	○	110	A12
20×20	●	●	125	A16
25×25	●	○	140	A20
32×32	○	○	170	A25

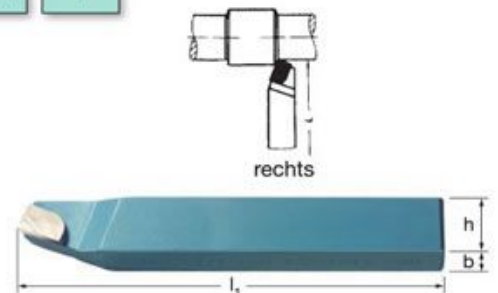

弯头车刀



HM DIN 4972 ISO 2

194120 PRECITOOL, 右向 P20

194160 PRECITOOL, 右向 K20

194170 PRECITOOL, 左向 P20

194190 PRECITOOL, 左向 K20

h×b mm	194120 (RG 1932)	194160 (RG 1932)	194170 (RG 1932)	194190 (RG 1932)	l ₁ mm	ISO/DIN-硬质合金刀片
10×10	●	●	●	●	90	C8
12×12	●	●	●	●	100	C10
16×16	●	●	●	●	110	C12
20×20	●	●	●	●	125	C16
25×25	●	●	●	●	140	C20
32×32	●	●	●	○	170	C25

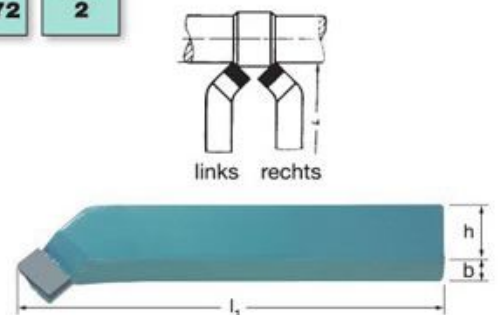

尖头车刀



HM DIN 4975

194220 PRECITOOL, P20

194260 PRECITOOL, K20

h×b mm	194220 (RG 1932)	194260 (RG 1932)	l ₁ mm	ISO/DIN-硬质合金刀片
16×10	●	●	110	E5
20×12	●	●	125	E6
25×16	●	○	140	E8

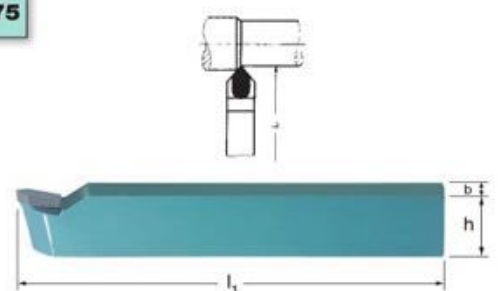

HM

DIN
4976ISO
4

194320 PRECITOOL, P20
194360 PRECITOOL, K20

h×b mm	194320 (RG 1932)	194360 (RG 1932)	l_1 mm	ISO/DIN-硬质合 金刀片
10×10	●	●	90	C10
12×12	●	●	100	C12
16×16	●	●	110	C16
20×20	●	●	125	C20
25×25	●	●	140	C25

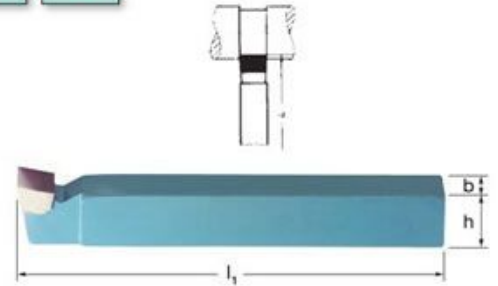

沉积车刀

HM

DIN
4977ISO
5

194420 PRECITOOL, 右向 P20
194450 PRECITOOL, 右向 K20
194470 PRECITOOL, 左向 P20
194490 PRECITOOL, 左向 K20

h×b mm	194420 (RG 1932)	194450 (RG 1932)	194470 (RG 1932)	194490 (RG 1932)	l_1 mm	ISO/DIN-硬质合 金刀片 R/L
16×16	●	○	○	○	110	A12/B12
20×20	●	●	●	○	125	A16/B16
25×25	●	○	○	○	140	A20/B20

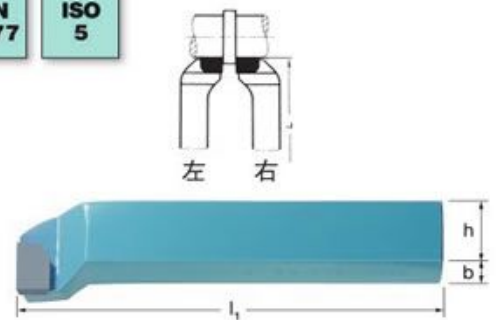

沉积侧向车刀

HM

DIN
4980ISO
6

194520 PRECITOOL, 右向 P20
194560 PRECITOOL, 右向 K20
194570 PRECITOOL, 左向P20
194590 PRECITOOL, 左向K20

h×b mm	194520 (RG 1932)	194560 (RG 1932)	194570 (RG 1932)	194590 (RG 1932)	l_1 mm	ISO/DIN-硬质合 金刀片 R/L
10×10	●	●	●	●	90	A8/B8
12×12	●	●	●	●	100	A10/B10
16×16	●	●	●	●	110	A12/B12
20×20	●	●	●	●	125	A16/B16
25×25	●	●	●	●	140	A20/B20
32×32	●	●	○	○	170	A25/B25

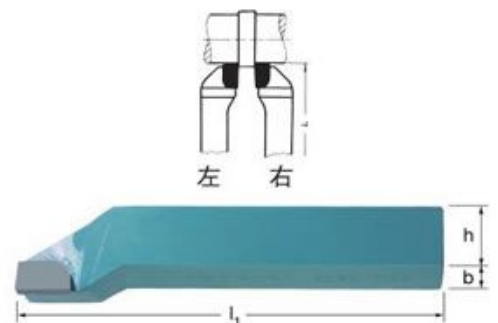

槽车刀

HM

DIN
4981ISO
7

194620 PRECITOOL, 右向 P20
194630 PRECITOOL, 左向P20
194640 PRECITOOL, 右向 P40
194650 PRECITOOL, 右向 K20
194670 PRECITOOL, 左向 K20

h×b mm	194620 (RG 1932)	194630 (RG 1932)	194640 (RG 1932)	194650 (RG 1932)	194670 (RG 1932)	l_1 mm	ISO/DIN-硬质合 金刀片 R/L
12×8	●	●	●	●	●	100	D3
16×10	●	●	●	●	●	110	D4
20×12	●	●	●	●	●	125	D5
25×16	●	●	●	●	●	140	D6
32×20	●	●	○	●	○	170	D8

